

Fig. 1

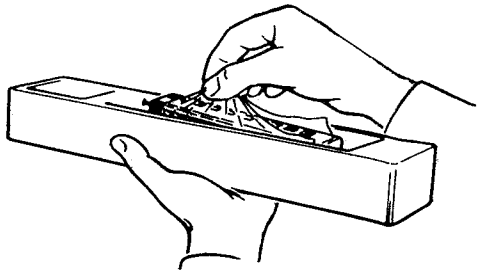

Fig. 2

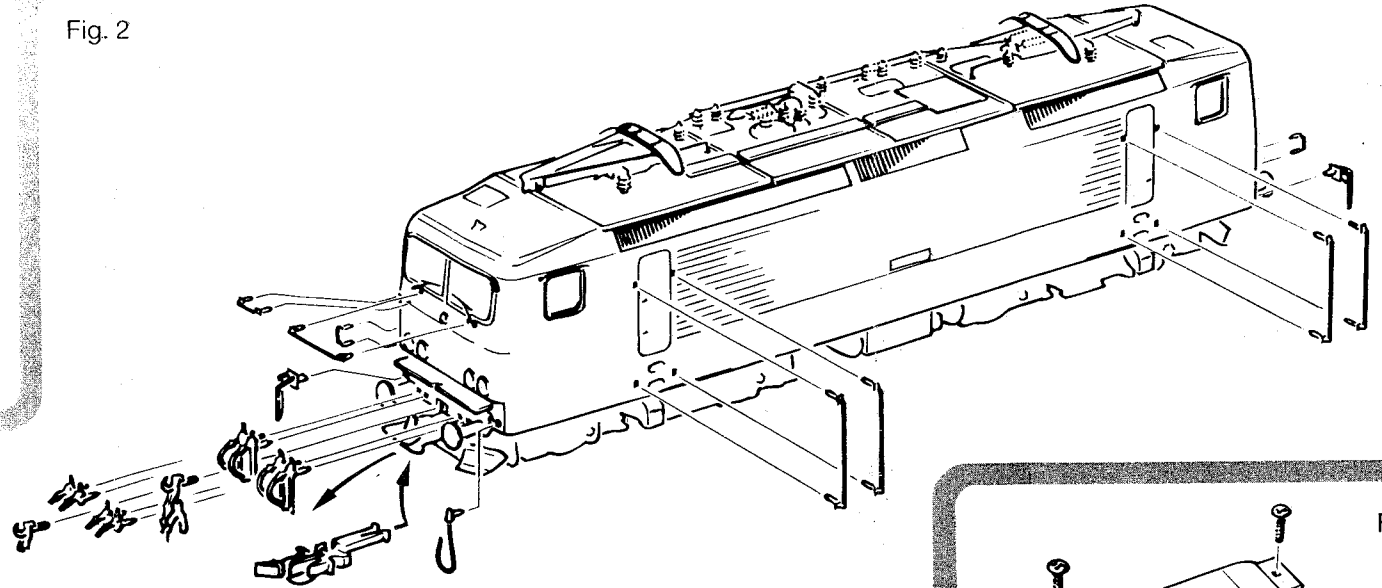

Fig. 3

Führerstand
Drivers compartment
Cabine du conducteur

1.

2.

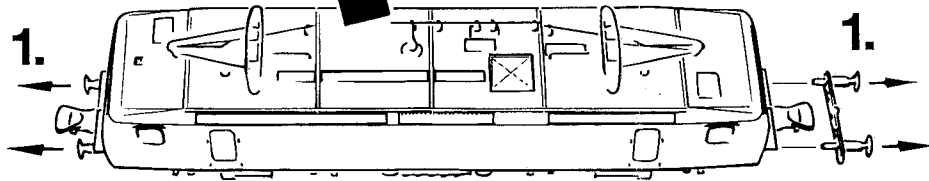

Fig. 5

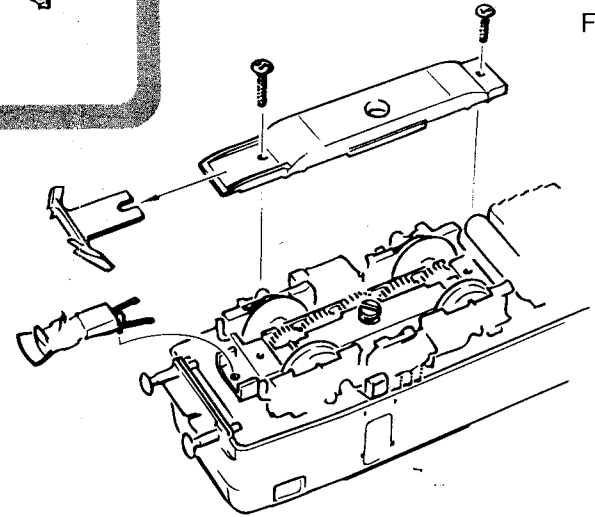
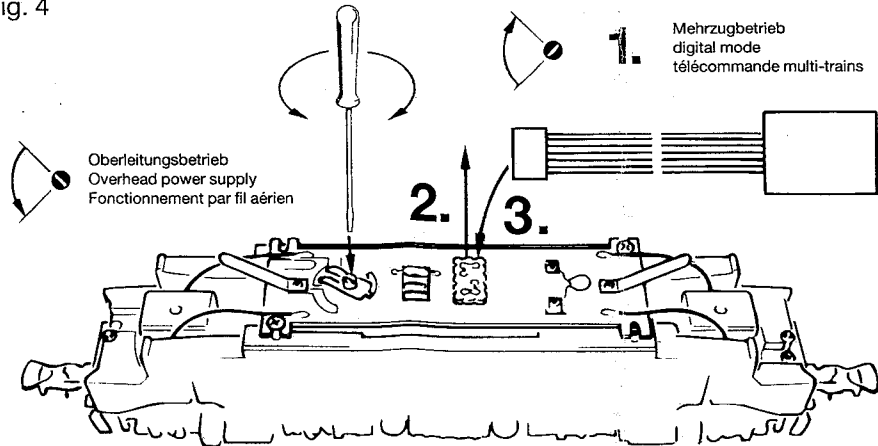

Fig. 4



1. Mehrzugbetrieb
digital mode
télécommande multi-trains

Oberleitungsbetrieb
Overhead power supply
Fonctionnement par fil aérien

Fig. 6

